

HiFi ENGINE®

For more Hi-Fi manuals and set-up information
please visit www.hifiengine.com

YAMAHA

CR2020

AM/FM Stereo Receiver

Owner's Manual

CENTER

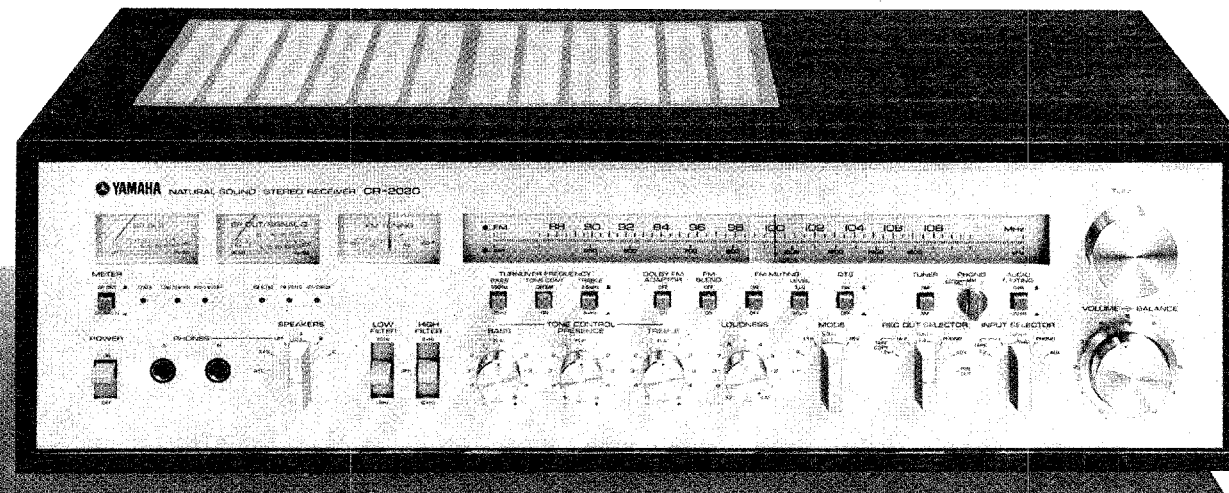

CR-2020

CONNECTION DIAGRAM

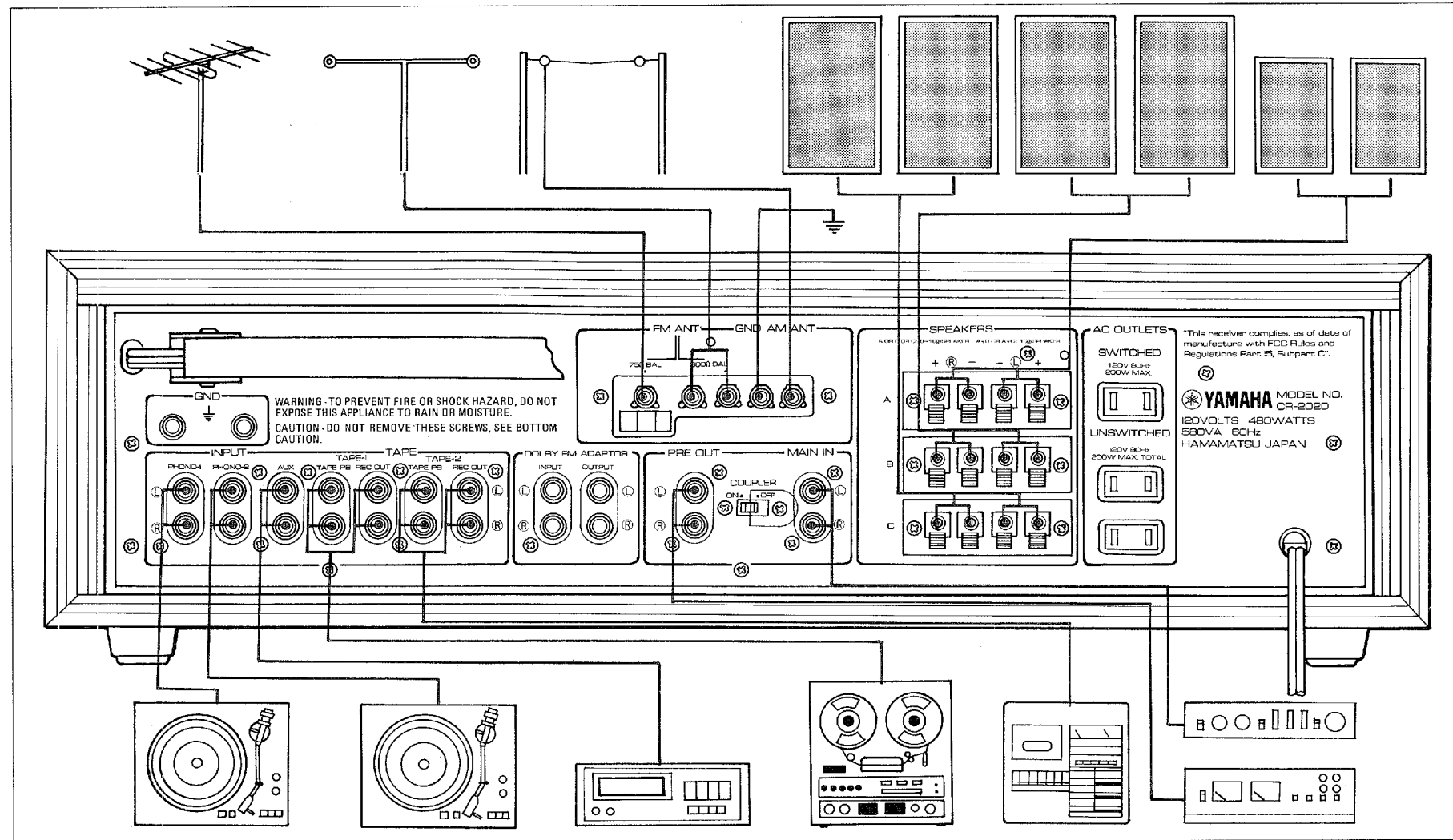

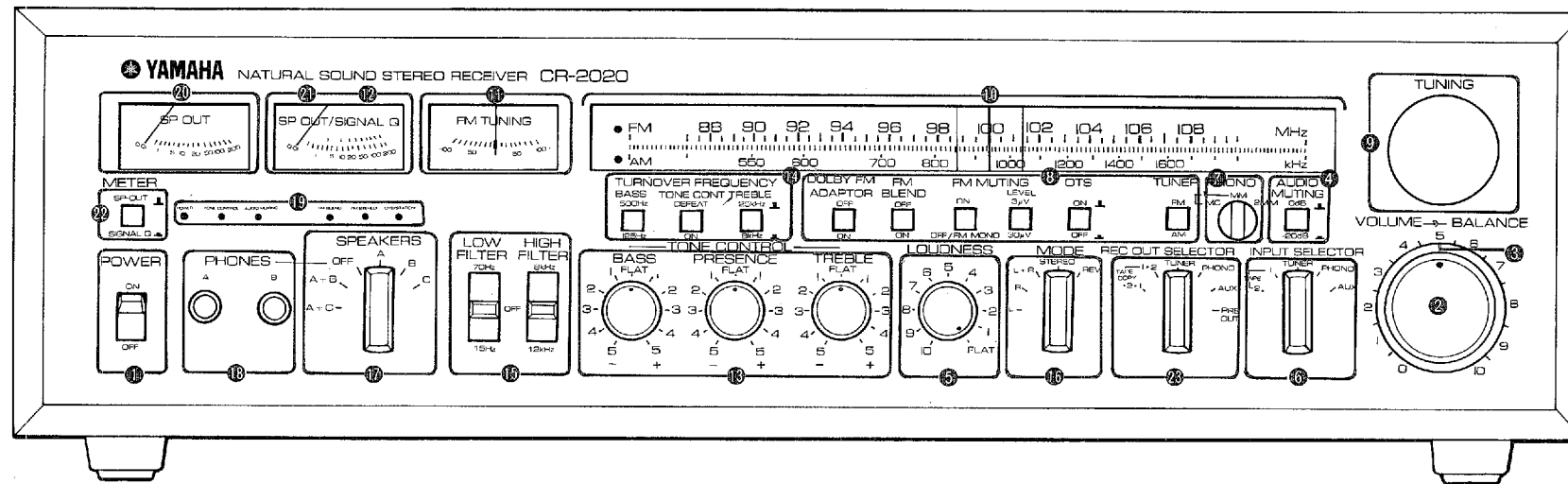

▲ FRONT PANEL Front panel numbers are explained on pages 6 and 7.

▼ REAR PANEL Rear panel numbers are explained on pages 8 and 9.

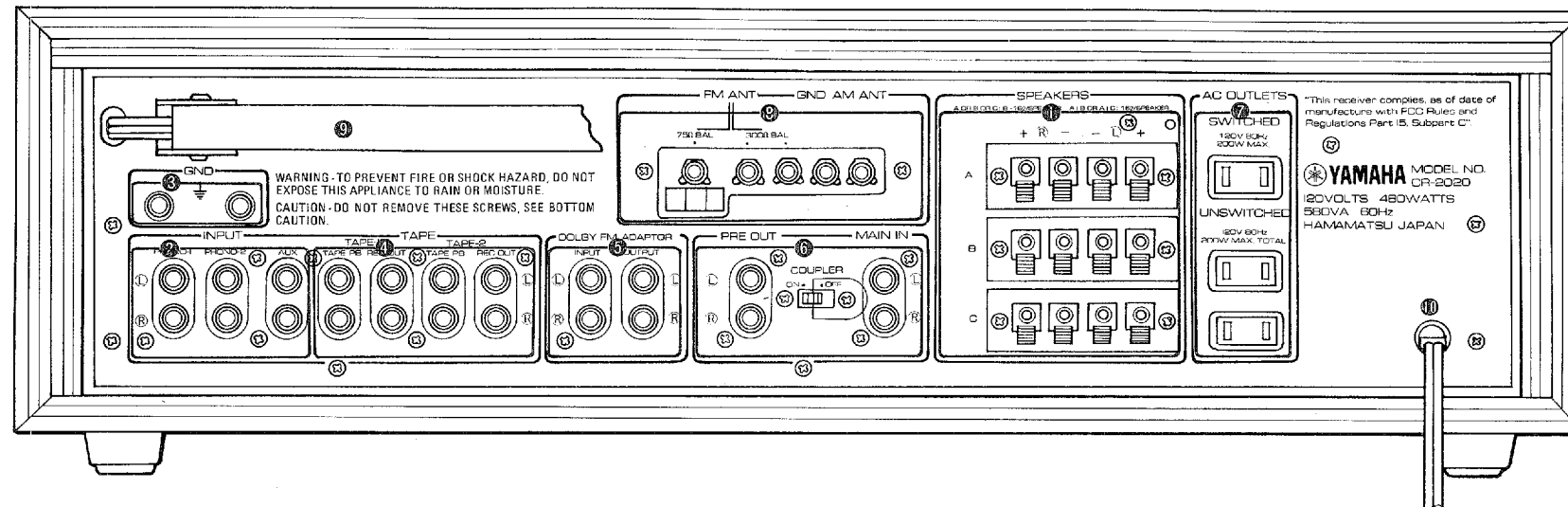

CR-2020

CONTENTS

YAMAHA offers you thanks and congratulations on your choice of the CR-2020 Receiver. Embodying novel and useful features, it combines superb broadcast reception with the finest audio quality, and is currently setting new standards for receiver performance in its class.

SPECIAL FEATURES OF THE CR-2020 RECEIVER

1. All-In-One Excellence

Accurately matched performance specifications, functions, and controls, give overall performance which fully measures up to Yamaha's high tuner, pre-, and power amp standards.

2. Noise-Distortion Clearance Range

This is the basic concept for the audio section. The CR-2020 offers an extremely wide range of output powers for which both noise and distortion are below the rated value, for wide dynamic range in actual use.

3. Direct Assessment of Differential Gain

This sophisticated technique enables Yamaha to combine high station-getting ability, razor-sharp tuning, and ultra-low distortion in the tuner section.

4. Optimum Tuning System

The OTS system will take over from you the fine-tuning needed to obtain minimum distortion and maximum stereo separation, so that all FM stereo programs are heard at their best.

5. Multi-Function Meters

Fast-response wide-level meters indicate power output levels from 0.05 W to 200 W (for 8-ohm speakers), with the right channel meter doubling as signal strength and (on FM) signal quality meter.

6. Super Low-Noise MC Head Amp

This IC unit makes the superior performance of low output moving coil cartridges yours without the cost of a separate step-up transformer or head amplifier.

7. Comprehensive Tone/Filter Controls

Both Bass and Treble controls have switched turnover frequencies (with defeat switch), and there is also a mid-frequency 'Presence' control. Dual High and Low Filter settings are provided.

8. Continuous Loudness Compensation

This Yamaha 'special' enables full compensation for the ears' reduced sensitivity to bass and treble frequencies at low listening levels, whatever your normal maximum listening level.

Front Panel and Controls	6
Rear Panel and Connections	8
Broadcast Reception	10
Speakers and Headphones	14
Listening to Records	15
The Special REC OUT Selector Switch	16
PRE OUT/MAIN IN COUPLER	
ON/OFF Switch	17
Tape Playback and Recording	18
Output Level Controls and Meters	20
Tone Controls	22
Filters and Mode Selection	23
Block Diagram	24
Circuit Diagram	25
Specifications	26
Trouble Shooting	28

Warning: to prevent fire or shock hazard, do not expose this set to rain or moisture.

CR-2020

CAUTIONS — READ THIS BEFORE OPERATING YOUR CR-2020

1

The CR-2020 is a high performance AM/FM stereo receiver, with excellent selectivity, sensitivity, low distortion, and high output power. This manual is required reading if you are to get the best from its special features and controls.

2

Do not drop or otherwise jar the CR-2020, which is a precision electronic instrument.

3

Do not place the CR-2020 where it will be exposed to direct sunlight, excessive heat (for instance over a radiator), cold, moisture, or dust.

4

Do not use chemical solvents (such as benzene or alcohol) to remove traces of dirt. Wipe only with a soft, slightly damp cloth.

5

Do not attempt to carry out internal adjustments or repairs. Leave these to your local service representative.

6

Do not assume your CR-2020 is faulty before checking the 'Trouble Shooting' list on pages 28 to 29 for common operating errors.

7

Operate all switches and knobs in accordance with the instructions. Avoid applying undue force, which should never be necessary, and do not attempt to use intermediate settings.

8

Note that the muting circuit keeps the CR-2020 silent for several seconds after switching ON, to prevent the pops and clicks that can occur.

9

Do not connect other audio equipment to the spare AC outlet sockets on the rear panel if they will require more power than the outlets are rated to provide.

10

Always check the main VOLUME setting before returning the AUDIO MUTING switch to the 0 dB position. The sudden increase in level is enough to damage most speakers with the 100 Watts rms which the CR-2020 provides if the original level was too high.

11

Keep this manual in a safe place for future reference, and refer to it frequently until you are perfectly familiar with all CR-2020 controls and functions.

CR-2020

FRONT PANEL AND CONTROLS

① POWER ON/OFF Switch

Switch ON to connect the main electrical supply. Leave OFF while familiarizing yourself with the controls, and while connecting other audio equipment.

② VOLUME Control

Use this control to give the volume of sound that you require. Always start with it turned fully to the left (counter-clockwise) at the '0' position before turning it up to the volume level you require.

③ BALANCE Control

This controls the balance between the L and R stereo channels. Set it to the center '5' position, at which there is a click stop, unless you need to emphasize the sound from one or other of the speakers.

④ AUDIO MUTING 0/-20 dB Switch

This gives a straight 20 dB reduction in listening volume without having to adjust the VOLUME control. Use it whenever operating selector or other switches, and when lowering the phono cartridge onto the record.

⑤ LOUDNESS Control

This boosts the extreme low and high frequencies to compensate for our ears' reduced sensitivity to

these frequencies at low volumes. Set it to the FLAT position while the VOLUME control is set to your normal listening level. Turning it counter-clockwise will reduce the volume but retain the natural balance between low and high frequencies.

⑥ INPUT SELECTOR

This switch is used to select the program source of your choice, whether PHONO, TUNER, one of two TAPE decks, or AUX (for 8-track tape cartridge playback, etc).

⑦ PHONO 1 MC/MM, 2 MM

Select PHONO terminals 1 or 2 with this switch once the INPUT SELECTOR switch has been set to PHONO. The PHONO 1 position offers a choice of low output moving coil (MC) cartridges or normal moving magnet (MM) types. PHONO 2 only handles MM cartridges.

⑧ The FM Tuner Section Controls

TUNER FM/AM: this determines whether AM (medium waveband) or FM stations will be received.

OTS ON/OFF: in the ON position, the Optimum Tuning System will correct any slight mis-tuning, to assure optimum reception of FM stations. In the OFF position, accurate manual tuning becomes necessary. Note that even in the ON position, OTS only comes into effect when you have

released the tuning knob.

FM MUTING LEVEL: at the 3 μ V setting inter-station noise and weak signal strength stations will be muted. At the 30 μ V setting only those stations capable of good stereo reception will be heard.

FM MUTING ON/OFF MONO: the 3/30 μ V settings require this switch to be ON. In the OFF MONO position all stations will be heard, but only in monaural mode.

FM BLEND: this switch is used to reduce the hiss noise that affects the weaker FM stereo stations.

DOLBY FM ADAPTOR: only if you have purchased and fitted an adaptor for FM 'Dolby' broadcasts should this switch be ON: without an adaptor the ON position will turn your FM tuner section off.

⑨ TUNING Knob

This large tuning knob gives smooth and positive station selection, with precision flywheel mechanism.

⑩ FM/AM Tuning Scale

The upper scale gives FM station frequencies in MHz and the lower scale gives AM frequencies in kHz, with LEDs at the left indicating the scale in use.

⑩ FM TUNING METER

This is used when tuning in FM stations: the indicator points to dead center when the station is perfectly in tune.

⑪ SP OUT/SIGNAL Q Meter

This meter indicates the strength of the signal for both AM and FM stations, and indicates FM interference by fluttering, with the amplitude of the variation showing the extent of the interference. It also doubles as an output level meter, see ⑳ and ㉑.

⑫ BASS, PRESENCE, and TREBLE Controls

In addition to normal bass and treble controls, there is PRESENCE control of the mid-frequencies.

⑬ TURNOVER FREQUENCY/ DEFEAT Switches

Select 125 or 500 Hz turnover frequencies (for bass) and 2.5 or 8 kHz (for treble), or defeat all tone controls including the mid-range PRESENCE control with the DEFEAT switch.

⑭ LOW and HIGH FILTER Switches

These give a choice of 15 or 70 Hz low frequency steep cut-off filters, and of 8 or 12 kHz for high frequencies.

⑮ MODE

In addition to normal stereophonic audition you can switch to reverse stereo, monaural (L + R), or to either left- or right-hand channel alone (L or R).

⑯ SPEAKERS

With this you can select any one or any pair of three sets of stereo speakers — or switch all off to enjoy headphone listening.

⑰ PHONES Jacks

Two headphone sockets are provided. Plugging in does not mute the speakers, so use the OFF position on the SPEAKERS switch. Remove the plastic protective cover before attempting to plug in.

⑱ LED Indicators

These give visible indication of whether the POWER is on, the TONE CONTROLS operative, the AUDIO MUTING on, the FM BLEND on, also indicating whether an FM stereo station is being received, and whether the OTS is on.

⑳ and ㉑ SP OUT Level Meters

These sensitive, wide-range meters measure the output power for each channel from 0.05 W to

200 W. The right-hand meter ㉑ also doubles as the signal strength and quality meter (changing over to this function when the tuning knob is touched). The left-hand meter does not indicate output power when the left-hand meter is in the signal Q mode.

㉒ METER Switch

Use the SIGNAL Q position for continuous signal strength and quality measurements. Use the SP OUT setting for right-hand channel levels (Note: the meter reverts back automatically when the tuning knob is touched).

㉓ REC OUT Selector

This selects the program source which will be recorded, just as the INPUT SELECTOR selects which program source will be heard. In the CR-2020 you can listen to one program while recording another (copy a friend's tape while listening to FM, etc.).

CR-2020

REAR PANEL AND CONNECTIONS

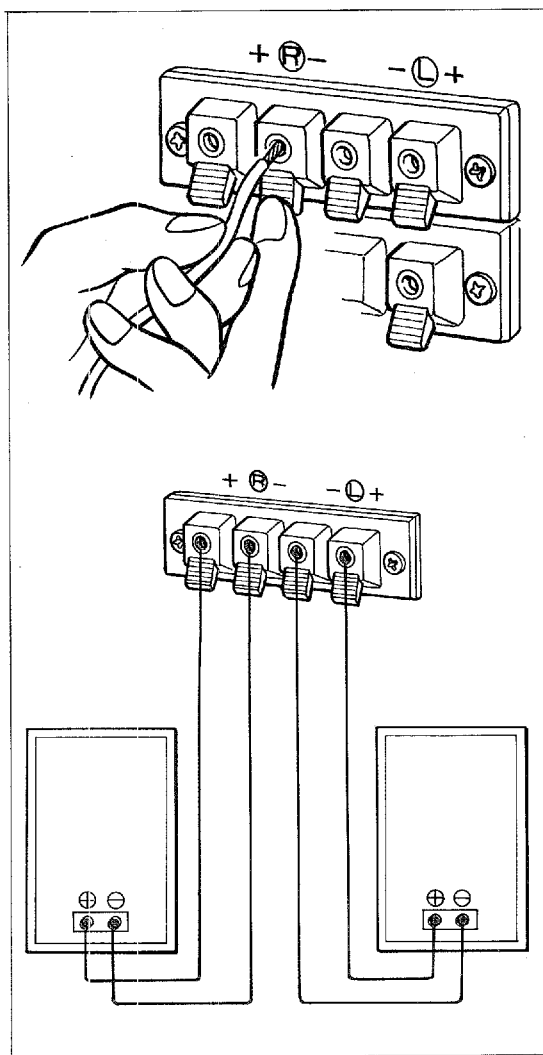

1 SPEAKERS Terminals

The complete instructions for connecting speaker systems to this receiver are given on page 14. However, if you wish to hear what your receiver sounds like now, you can hook up your speakers to the A terminals on the rear of your CR-2020. Only use speakers with impedances between 8 and 16 ohms, and preferably rated to take 100 Watts. If not, use the VOLUME control so that their rated maximum input power is not exceeded on the meter readings. Remember that the meters are calibrated for 8 ohm speakers. Halve the value for 16 ohms.

To connect the speakers, push the lever beneath the terminals as shown in the diagram, align the inner and outer terminal holes, and insert the speaker wire into the holes. Then release the lever, which clamps the wire.

Make sure that you connect the + terminal on the receiver to the + terminal on the speaker, and the - terminal on the receiver to the - terminal on the speaker. A mistake here will result in poor bass response and an ill-defined stereo image. Also make sure that you connect the left-hand speaker to the left-hand channel, and the right-hand similarly.

2 INPUT Terminals

These are the terminals selected by the INPUT SELECTOR and PHONO switches on the front panel. Use the PHONO-1 terminals first, keeping PHONO-2 as a spare. The shorting plugs in the PHONO-2 terminals should be left in place unless these terminals are used. The AUX terminals can be used to connect an external tuner, or for 8-track cartridge tape playback, etc.

3 Ground (GND) Terminals

Two ground terminals are provided for grounding turntable units, etc. Please make sure that all such units are firmly grounded: failure to connect the ground leads can result in unpleasant hum.

4 TAPE PB and REC OUT Terminals

Two tape decks can be attached to these input and output terminals. Recordings can be made on both at the same time, of any source connected to the CR-2020, and tapes can be dubbed from one to the other in both directions.

5 DOLBY FM ADAPTOR Terminals

If you purchase an adaptor designed to enable you to receive Dolby FM broadcasts, it should be connected to these terminals, and the corresponding switch on the front panel should also be depressed during Dolby FM broadcasts.

6 PRE OUT and MAIN IN Terminals

The preamplifier section output is always available from the PRE OUT terminals, but unless the COUPLER switch is OFF, the output from another preamplifier cannot be fed to the power (MAIN) section. The plastic guard is to stop you switching off accidentally.

7 AC OUTLETS

The top (200 W maximum) outlet is controlled by the CR-2020 POWER switch. The two lower outlets (200 W maximum total) are unswitched. Use them for other audio equipment but do not exceed the rated loads.

8 ANTENNA CONNECTIONS

Detailed instructions on AM and FM reception are given on pages 10 to 13, but a quick check of CR-2020 functions can be carried out by connecting the T-type internal (indoor) antenna provided with the CR-2020 to the terminals marked 300 Ω BAL. Pin the two arms of the 'T' at full stretch to the ceiling or walls of your room after finding the best orientation. Note that such a quick check can be carried out with all selector switches vertical and all push switches in the out (non-depressed) positions.

9 Bar Antenna for AM Reception

This internal antenna will usually be adequate for satisfactory AM reception. It should be swung away from the rear panel on the hinge provided.

10 AC Electrical Power Line

Just plug in to a main power supply wall outlet socket. Be sure the line is not placed where you might trip over it.

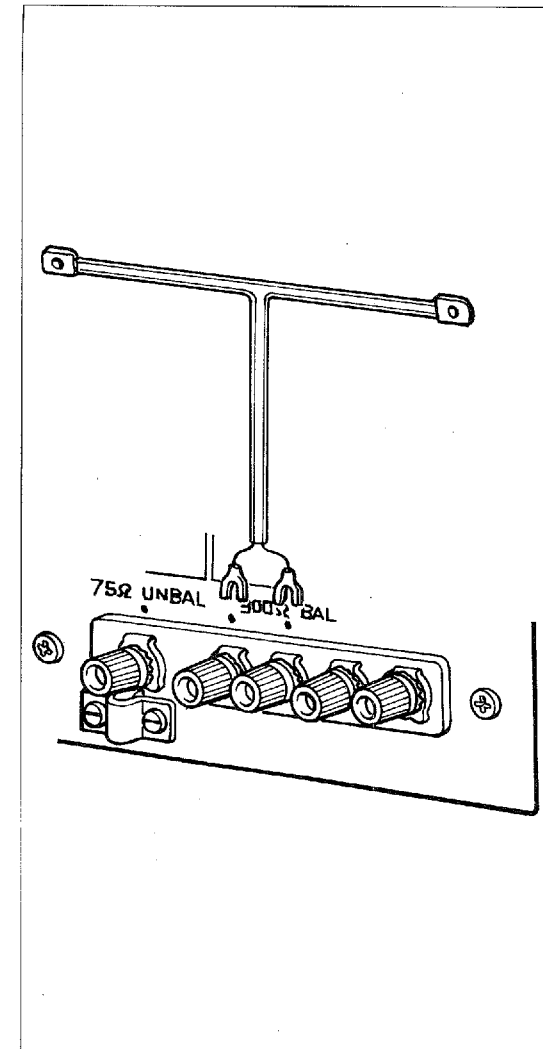

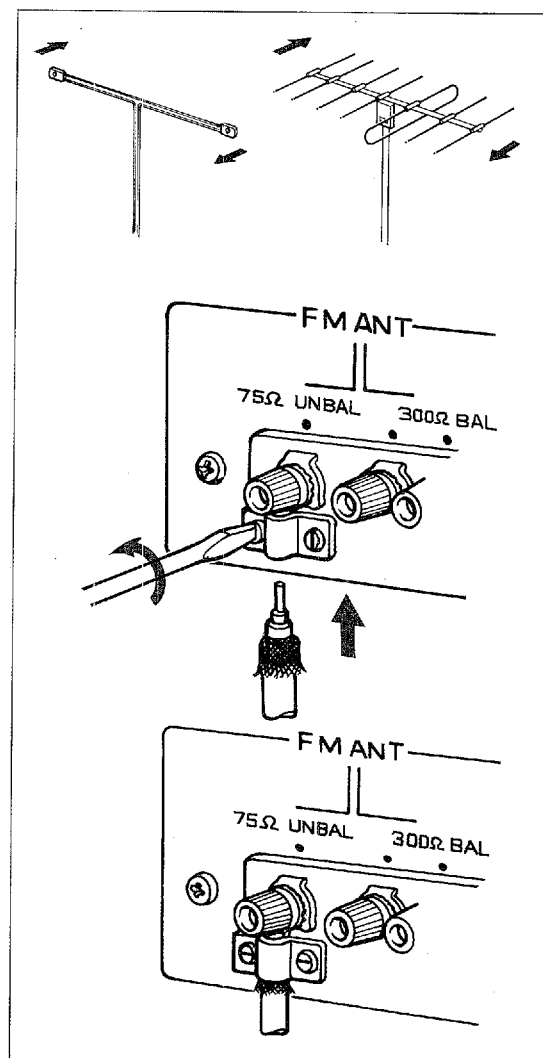

CONNECTING AN FM ANTENNA

The T-type antenna provided is adequate only in high signal strength areas under favorable conditions. In other cases, an external multi-element FM antenna is needed. If you cannot obtain satisfactory reception with the T-type antenna after trying it in different positions, and orienting it to give the best reception for the weakest station to which you will normally be listening, this is an indication that you need an external FM antenna. The external antenna should be located as close as convenient to the CR-2020, and as high as possible. It should be oriented to give the highest reading possible for the weakest station to which you will normally be listening. If this direction is not too critical, you can orient the antenna for minimum interference from automobile ignition, etc.

If the antenna is intended for use with the shielded coaxial cable which reduces losses and interference, use the 75 Ω UNBAL terminals, and connect the cable as shown. Antennas intended for 300 Ω

BAL terminals (using feeder wire like that of the internal antenna provided) can also be used with coaxial cable, but a matching transformer is necessary at the antenna. Coaxial cable is advisable where the antenna must be located some distance from the CR-2020, or where interference from automobile ignition, etc., is troublesome.

CONNECTING COAXIAL CABLE

1. Strip insulation from the outside of the braided sheath, and bend back the metal braiding *outside* the insulation. Expose the projecting central core wire as shown, being careful not to cut through any strands in the process.
2. Slacken the two retaining screws as shown, insert the coaxial cable, and re-tighten the screws so that the clip grips the exposed braided sheath.
3. Connect the central core wire to the 75 Ω terminal.
4. Ensure that the braiding does not come into contact with the inner core.

FM BROADCAST RECEPTION

1. Set the INPUT SELECTOR ⑥ to TUNER, and the TUNER push-button to FM. Note that the FM indicator at the left of the tuning scale is lit.
2. All other push-buttons should be fully OUT (i.e. non-depressed) and the switches and knobs should be in the settings shown in the fold-out diagram of the front panel.
3. Touch the tuning knob and note that the OTS/STATION light goes out. Also the central meter will revert to its SIGNAL Q function.
4. Tune for maximum signal strength on the SIGNAL Q meter, ignoring any regular fluctuations which may occur.
5. Now tune to bring the FM TUNING meter pointer to the exact center. This is the optimum tuning position, and should be carefully set. Note that the OTS/STATION indicator glows faintly. Also note whether the FM STEREO indicator lamp lights: if it does, you have tuned to a stereo broadcast.
6. Release the tuning knob and the central meter will cease to read signal levels. Also the OTS/STATION lamp will glow brightly, indicating that the OTS (Optimum Tuning System) has gone into action to ensure that the optimum tuning position is maintained.

OTS ON/OFF SWITCH

This push-button switch should normally be left in the ON (non-depressed) position. If pushed into the OFF position, it will over-ride the OTS circuits, allowing full manual tuning, but preventing the automatic correction of slight mis-tuning and any undue influence of changes in temperature and humidity. Use the OFF position to tune in weak stations near strong local stations which might otherwise be 'pulled in' by OTS.

FM BLEND

When you are listening to a weak FM station in stereo, there can be unpleasant high frequency noise (a kind of 'hiss'). If this hiss noise is bothering you, push the FM BLEND switch in to the ON position. At a slight sacrifice of the high frequency inter-channel stereo separation, noise will be considerably reduced. Note that the FM BLEND indicator will light.

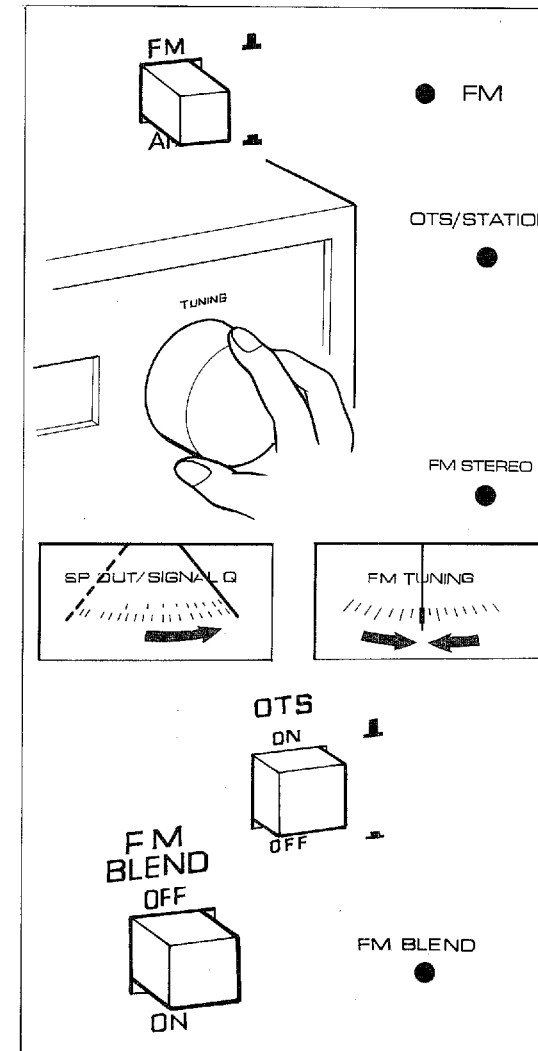

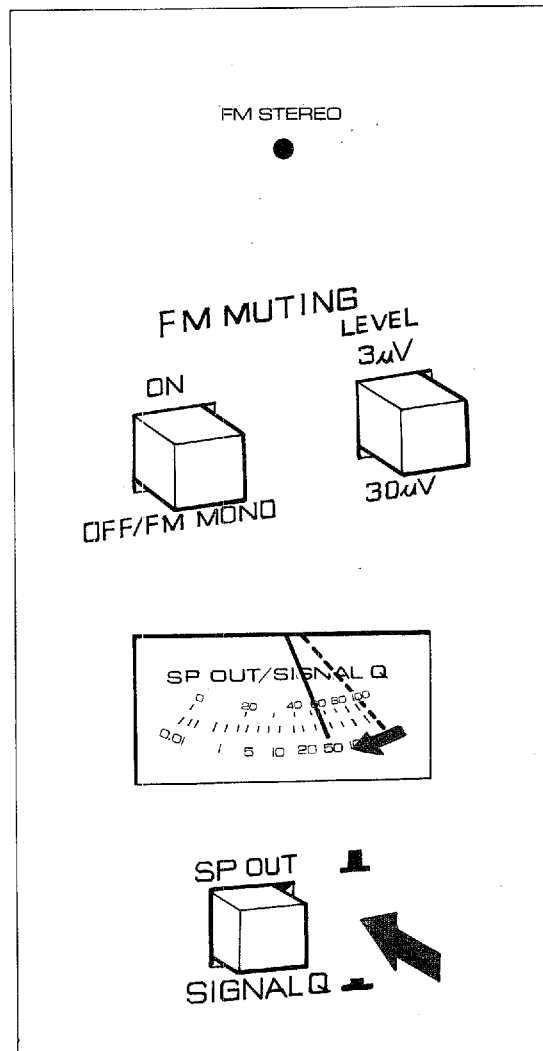

FM MUTING ON-OFF/MONO

If a further reduction in noise is desirable, press the FM MUTING push-button to the OFF/MONO position. You will be able to receive weak stations with the lowest possible noise levels, but as the name of the switch indicates, only in the monaural mode. And although the on-station noise will be reduced, you will notice much more 'static' interference between stations. This inter-station noise is normally blanked out by the muting circuit when ON.

FM MUTING LEVEL 3/30 μ V

If you decide that the weakest stations cannot give you sufficient listening enjoyment, set the FM MUTING LEVEL push-button on 3 μ V. The weakest stations will be cut out, with the inter-station noise. If you wish to reduce the number of stations even more, to those capable of good stereo-reception, set the LEVEL to 30 μ V. You will be able to tune from stereo station to station, sure of good quality reception, free of background noise and remote, poor quality stations.

SIGNAL QUALITY

So-called 'multipath' waves, reflected from nearby hills or tall buildings, can seriously degrade tonal quality in FM reception. In addition to the obvious deterioration in tonal quality, the SIGNAL Q meter can also give you a clear visual indication of the presence of this and other kinds of interference. The indication will fluctuate, in serious cases quite considerably. Since the signal strength indication is fairly linear, there is a very wide range of signal strengths for which this indication is available.

If you notice variations in the SIGNAL Q reading, first switch the METER push-button ② to SIGNAL Q, so that the meter continually indicates signal strength, without you needing to touch the tuning knob. Then try different antenna orientations. You will generally enjoy better tonal quality if you orient the antenna to give a steady reading, even if this level is a little lower than the maximum when the indication is fluctuating.

FM DOLBY ADAPTOR

If you purchase a suitable 'FM DOLBY' adaptor designed to make the best of DOLBY-type broadcasts, it should be plugged into the appropriate pin-jacks on the rear panel, and the switch on the front panel should be pushed in. Leave it OFF (out) if you do not have an adaptor: mistakenly pushing it ON will prevent normal audition of FM programs.

AM RECEPTION

1. Set the TUNER FM/AM switch to AM.
2. Set the tuning indicator to the station frequency.
3. Adjust the tuning knob to give the maximum SIGNAL meter reading.
4. Note that the FM TUNING meter does not work for AM stations.

AM BAR OR EXTERNAL ANTENNA

The high efficiency ferrite bar antenna provided with the CR-2020 is all that is required for satisfactory reception except in low signal strength areas, so that usually no external AM antenna will be needed. The bar antenna is hinged to the rear panel so that it can swing out: try swinging it while watching the SIGNAL Q meter (remember to switch the METER push-button to the SIGNAL Q position so that you can remove your hand from the tuning knob). Set it at the angle giving the maximum reading for the weakest station to which you will normally be listening.

If satisfactory reception cannot be obtained, try connecting an external AM antenna to the AM ANT terminal. Even better results will be obtained if, at the same time, a good ground (or 'earth') connection can be made. A good connection can sometimes be made to a water pipe. However, NEVER attempt to make a ground connection to a gas pipe. Your dealer will advise you.

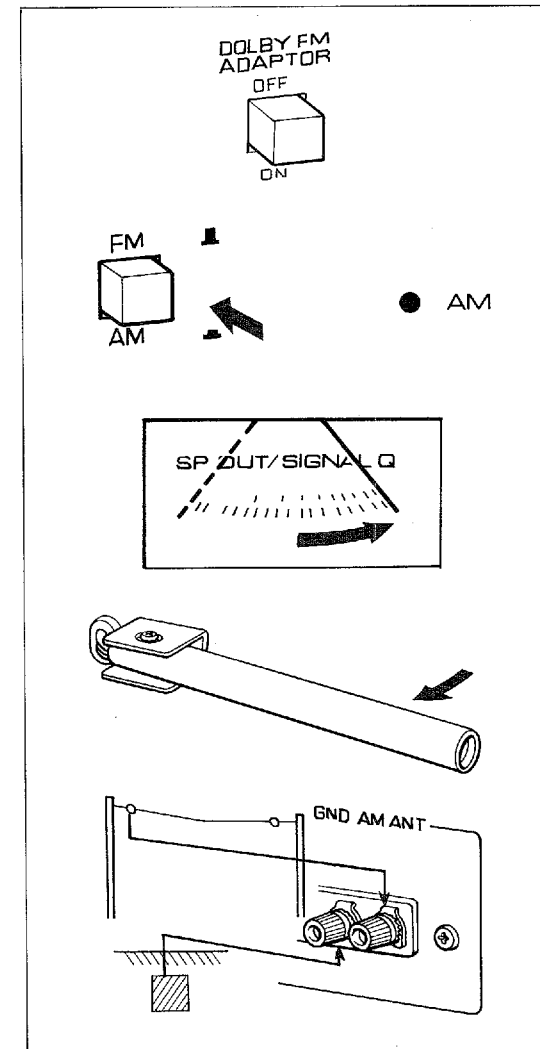

CR-2020

SPEAKERS AND HEADPHONES

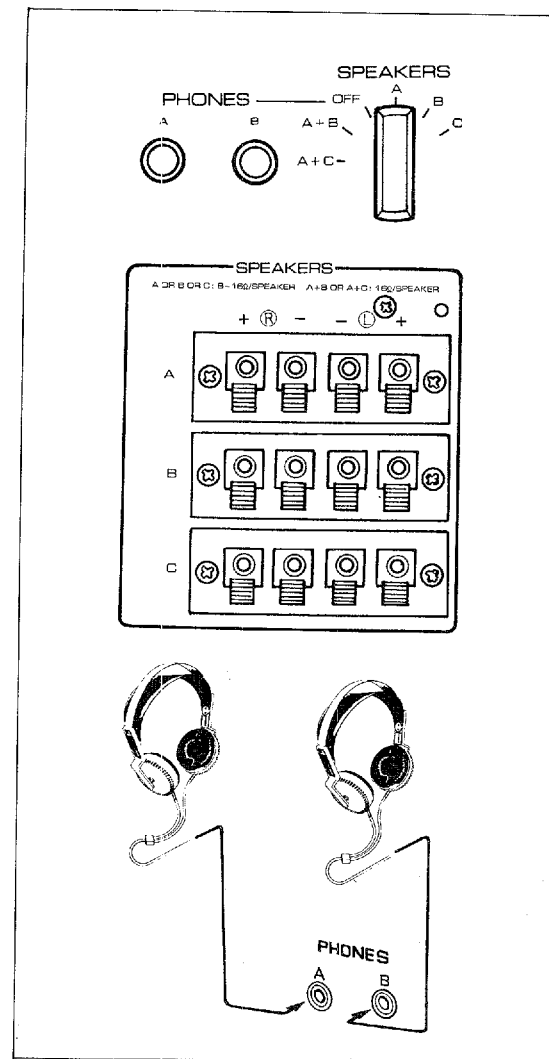

SELECTION OF SPEAKERS

The CR-2020 can handle three sets of speakers (A, B, and C), with selection of any one or two sets by the SPEAKERS switch on the front panel.

The CR-2020 is designed for speakers with impedances between 8 and 16 ohms when connected to either A, B, or C terminals. If two sets are to be played at the same time, however, please use only 16 ohm speakers.

Use speakers rated to take the full 100 Watts of output power, or set the VOLUME control so that the rated maximum speaker input power is not exceeded, as indicated by the meter readings. Remember that the meters are calibrated for 8 ohm speakers, so that with 8 ohm speakers the reading must be and halved for 16 ohm speakers.

MAKING THE SPEAKER CONNECTIONS

1. Strip the insulated covering from the speaker connecting cable for approx. 1/2" or 10 mm, and twist all stray ends together. If possible apply solder to the exposed 1/2" (10 mm). Push the lever beneath the terminal, and align the inner and outer terminal holes.

Then insert the wire fully home. Release the lever, and the wire end will be fully and firmly gripped, making a perfect connection.

2. Use the upper (A) terminals first. Be careful that the terminals identified by the + and - signs above them are connected with the + and - terminals on the speakers. A mistake will result in poor bass response and ill-defined stereo image. Also be sure to connect the left-hand speaker to the L speaker terminals, and the right-hand to the R terminals.
3. Repeat this with the B and C terminals if other speakers are to be connected. In all cases make sure that connections are fully and firmly made, or you may not be able to get any sound from one or more speakers.

HEADPHONES

First, remove the plastic phone jack guard.

Two pairs of stereo headphones may be connected to the CR-2020 simultaneously, but inserting the headphone jack plug does not switch off the speakers, which must be switched off by using the OFF position of the SPEAKERS selector switch. Orthodynamic headphones of the Yamaha HP series (HP-1 or 2) are recommended, but all conventional headphones are also suitable.

CR-2020

LISTENING TO RECORDS

CONNECTING A TURNTABLE UNIT

The main AC supply plug of your turntable unit may conveniently be inserted into the spare AC outlet socket controlled by the CR-2020 POWER switch. The output lead from the turntable unit should be connected to the PHONO 1 terminals, keeping the PHONO 2 terminals as spares. Check that the L and R pin plugs have been correctly inserted. Do not forget to connect the turntable ground line to one of the two GND terminals on the CR-2020.

Switch on the receiver POWER switch, and set the INPUT SELECTOR switch to PHONO. The PHONO switch offers a choice of MM, MC, and PHONO 2 positions. Use the MM position for moving magnet, moving iron, or induced magnet cartridges. Use the MC position if your tonearm is fitted with a low output moving coil cartridge. If you use this position you will not need a step-up transformer to boost the cartridge output. Consult your dealer if in doubt. The PHONO 2 terminals should only be used with MM etc. (not MC) cartridges. The shorting plugs in the PHONO 2 terminals should be left in place unless these terminals are used. Note that PHONO input plugs should *never* be connected or disconnected while the POWER switch is ON.

Use the AUDIO MUTING push-button switch to cut the volume instantly by 20 dB while changing records or altering the PHONO switch, etc., without having to turn down the volume each time. Do not switch from the MM setting to the MC setting while playing a record with a moving magnet or other such cartridge: the sudden increase in volume would seriously overload the CR-2020, and result in quite unacceptable distortion.

If you play monaural records, the signal-to-noise ratio will be improved if you turn the MODE selector switch to the monaural (L + R) position. Use either the 15 Hz or 70 Hz LOW filter to cut out any low frequency rumble, and use BASS, TREBLE and PRESENCE controls to give the best tonal balance. Use the LOUDNESS volume control to reduce listening levels below your normal maximum, not the main volume control.

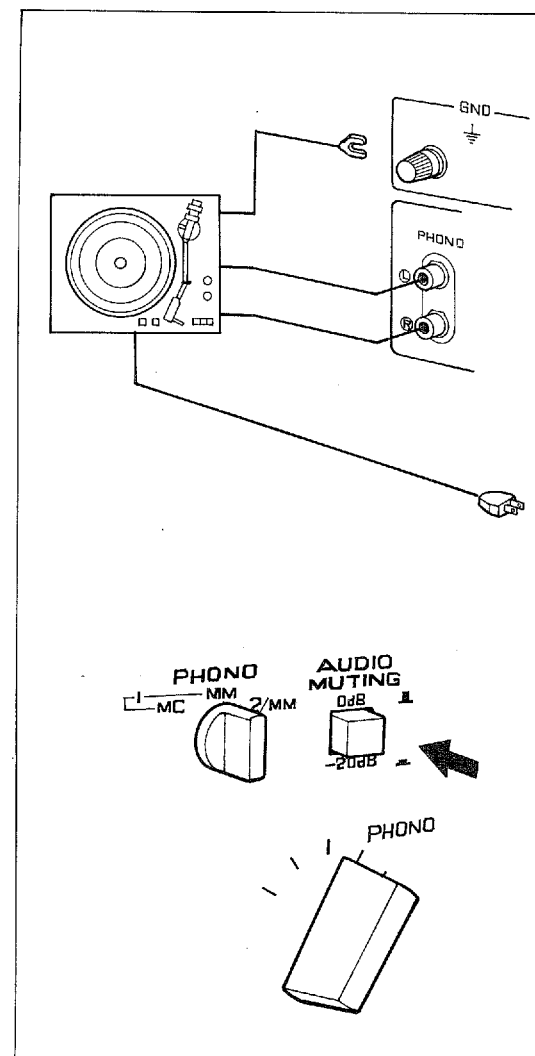

CR-2020

THE SPECIAL REC OUT SELECTOR SWITCH

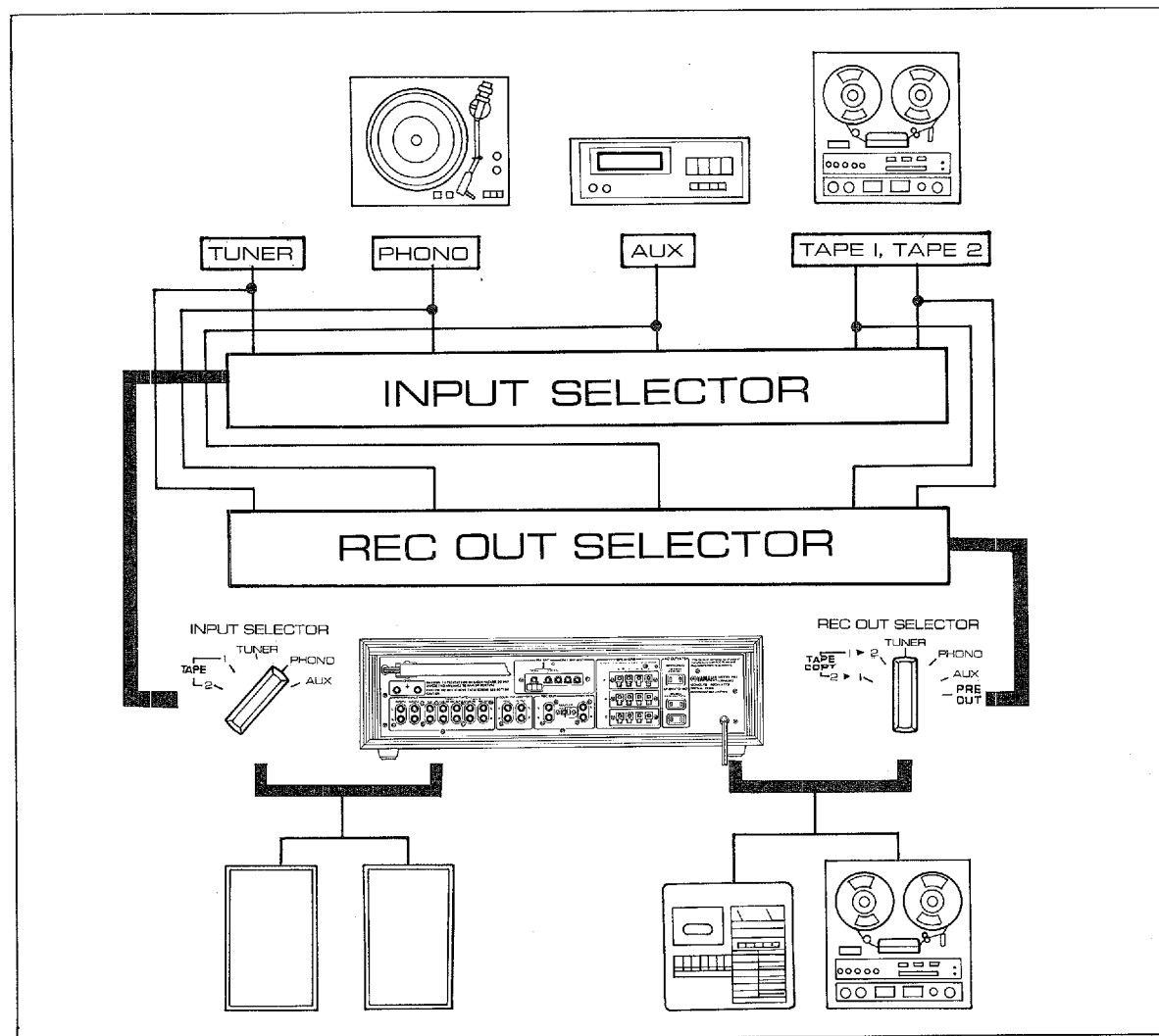

INDEPENDENT AUDITION AND RECORDING

Do not confuse the REC OUT and INPUT SELECTOR switches. The INPUT SELECTOR switch decides which program source you hear. The REC OUT switch decides which one you record. Yamaha receivers are at present unique in offering independent choice of audition and recording. Thus you can listen to a record while tape recording direct from the AM/FM tuner section, or while dubbing from one tape recorder to another (set the INPUT switch to PHONO and the REC OUT to TUNER, TAPE 1 ► 2, or TAPE 2 ► 1 positions). Alternatively you can tape record a disc while listening to, say, an FM broadcast or a music tape played back on a second tape deck (but be careful that you do not infringe copyright laws in tape recording proprietary material). Just set the REC OUT switch to PHONO and the INPUT switch to TUNER or TAPE (1 or 2) respectively.

When the REC OUT selector is set to the PRE OUT position, the tape decks will record the chosen program signal *after* it has been subject to the tone, filter, and volume controls of the CR-2020 preamplifier section.

CR-2020

PRE OUT/MAIN IN COUPLER ON/OFF SWITCH

SEPARATE OPERATION OF PRE- AND POWER SECTIONS

After the program signal has passed through the tone, filter, and volume controls it is fed to the power amplifier section. At the same time, it also appears at the PRE OUT terminals on the rear panel, where it is always available to drive a second power amplifier, or for connection to an oscilloscope or electronic frequency divider unit, etc.

This is true whether the COUPLER switch is ON or OFF. However, the MAIN IN terminals remain isolated as long as the COUPLER switch is in the ON position, so that the signal from the preamplifier section is amplified in the normal way. In the OFF position the coupling between pre- and power sections is broken, and any suitable signal may be applied to the MAIN IN terminals for amplification.

The plastic guard prevents this switch being mistakenly switched OFF. Switch it off only when you wish to connect other preamplifiers or power amplifiers for comparison, or when you wish to interpose a graphic equalizer or other audio component between the pre- and power sections.

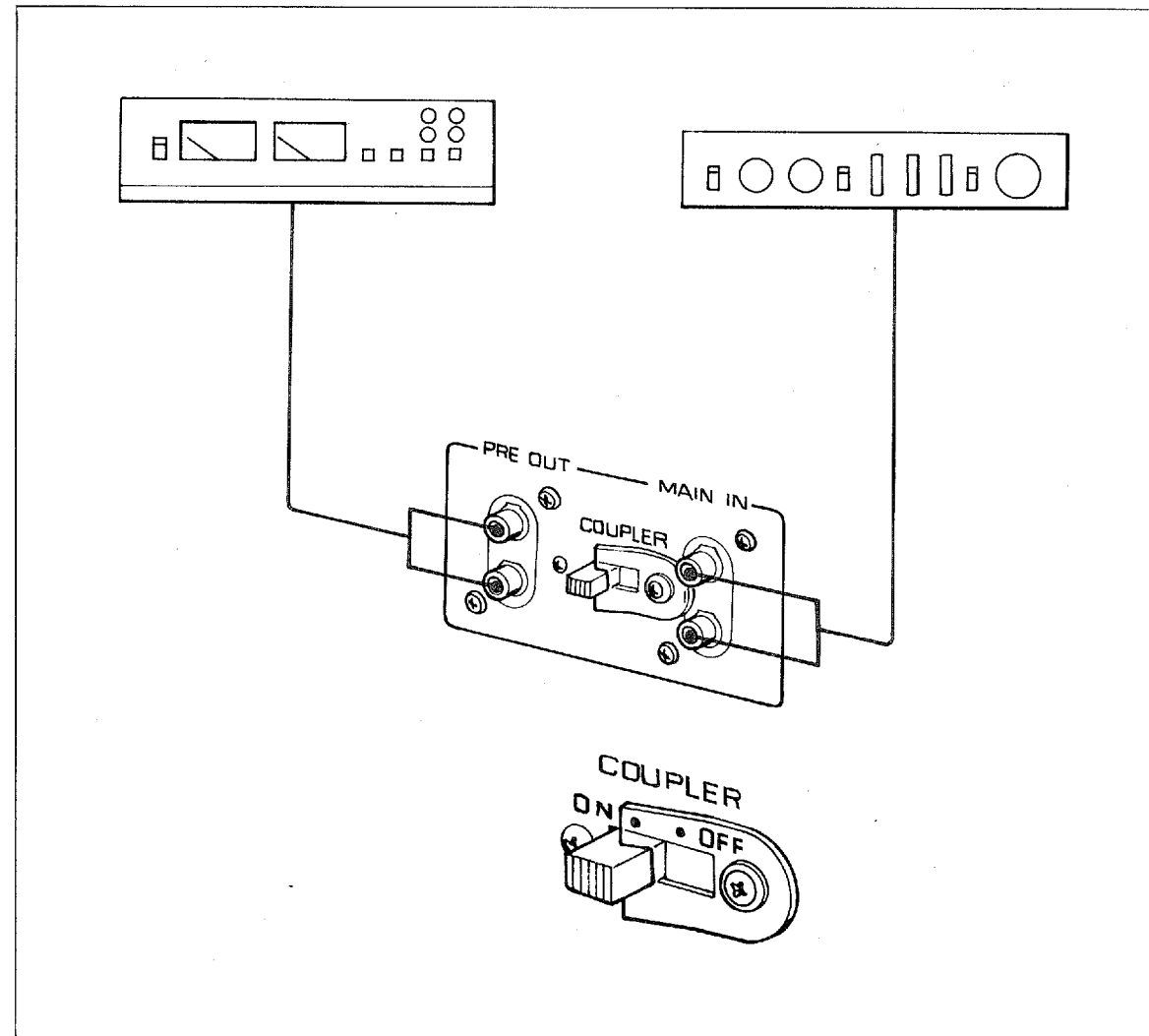

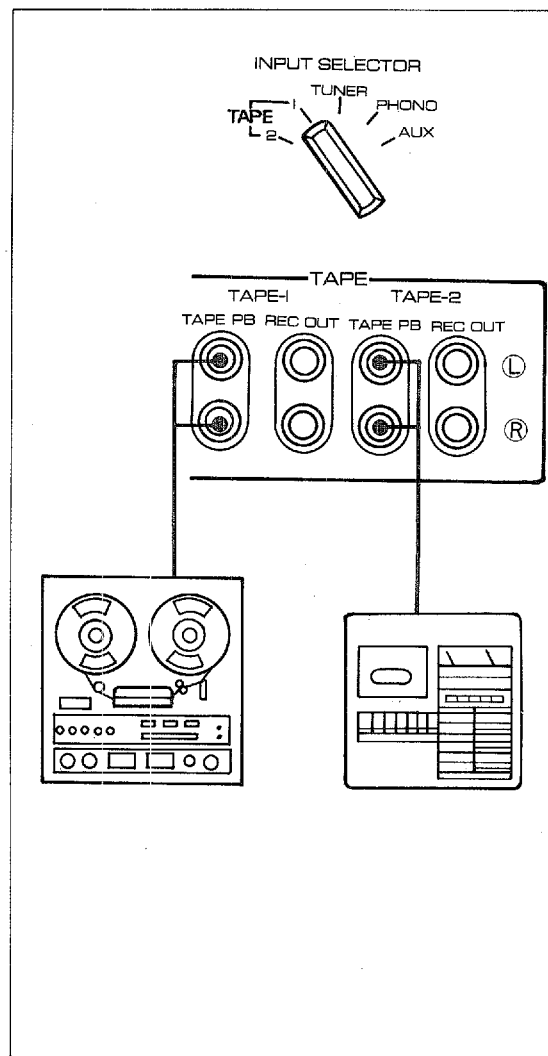

TAPE DECK CONNECTION/PLAYBACK

The output leads provided with the tape deck are used to connect the deck LINE output terminals to the TAPE PB terminals. Use the TAPE 1 terminals for your main deck. Use the TAPE 2 terminals for a second deck or as a spare pair. Set the INPUT SELECTOR to TAPE 1 to play back tapes (or to TAPE 2 if you are using the TAPE 2 terminals, of course). Use the output level controls on the deck or decks to adjust the playback level so that there is no great change in volume level when switching between TUNER and TAPE 1 or 2 terminals.

TAPE DECK CONNECTION/RECORDING

The tape-deck leads provided are used to connect the deck LINE input terminals to the REC OUT terminals. Again, you should use the TAPE 1

terminals for your main deck, keeping the TAPE 2 terminals for a second or spare pair. Note that the INPUT SELECTOR switch setting has *no effect whatever* upon the signal which will be recorded via these terminals. The REC OUT terminals' signal is decided by the REC OUT selector switch. If you refer to the description of the REC OUT function on the previous page you will see that recording of any of the program sources connected to the CR-2020 is possible: just set the REC OUT switch to TUNER, PHONO, or AUX, respectively.

Recording of any of these sources can proceed while that source, or any other, is selected for audition by the INPUT SELECTOR switch. Monitoring of the recording while it is in progress can be carried out, if you are using a three-head deck designed for monitoring, by setting the INPUT SELECTOR switch to the TAPE position, 1 or 2, via which you are recording. (Note: most cassette tape decks have only two heads, and

monitoring is impossible; most open-reel decks do have three heads, with one for monitoring.)

The level at which a recording is made is very important (see the instruction manual provided with your tape recorder). Adjustments in level should normally be made with the input level controls on the tape deck. The CR-2020 tone, filter, and level controls are only operative for the PRE OUT position of the REC OUT switch. By using the PRE OUT position you gain the convenience of being able to set levels, and alter tonal balance of the recording, using filters, etc., but you are limited to the program source selected by the INPUT SELECTOR switch. Also you will not be able to monitor your recording. This, and the fact that tone and filter controls inevitably introduce some extra distortion (although very little in the CR-2020!), means that you should normally record via the other positions of the REC OUT switch, using the PRE OUT setting only when it is really necessary, for instance when level adjustment is essential to prevent distortion, etc.

TAPE TO-TAPE DUBBING

For this you will need two decks. Check carefully that the L (left) and R (right) channel pin-jacks are correctly connected before commencing recording. To copy a tape from TAPE 1 to TAPE 2 terminals, use the TAPE 1 ► 2 setting on the REC OUT selector switch. Similarly, to copy from TAPE 2 to TAPE 1, use the TAPE 2 ► 1 setting. In both cases you can compare the original recording and the copy by switching the INPUT SELECTOR between the TAPE 1 and TAPE 2 settings (provided, again, that you have decks which allow you to monitor). Note that the original and the copy are reversed when copying in the opposite direction. Once you are satisfied that the recording is proceeding satisfactorily, you can turn the INPUT SELECTOR switch to any other program source you wish to enjoy, and the recording will not be affected.

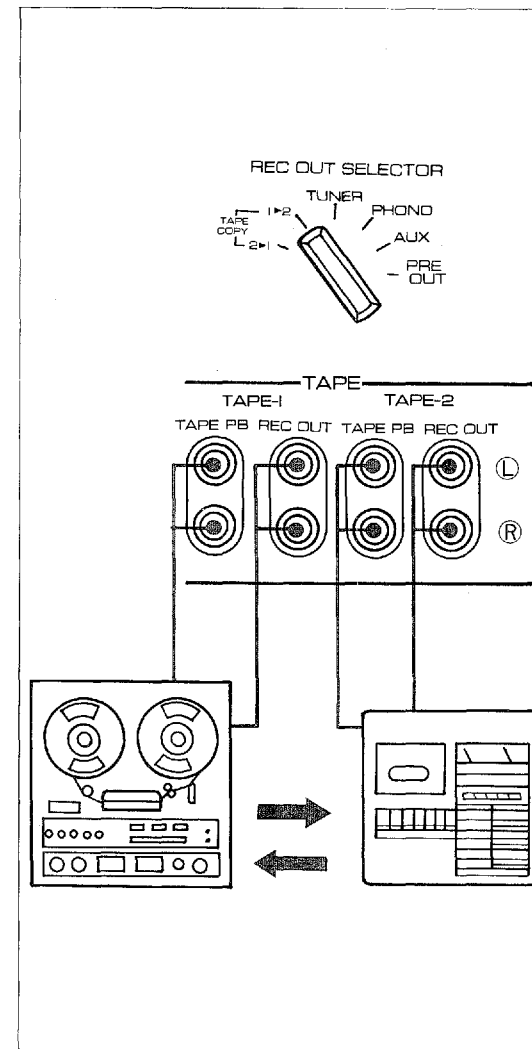

CR-2020

OUTPUT LEVEL CONTROLS AND METERS

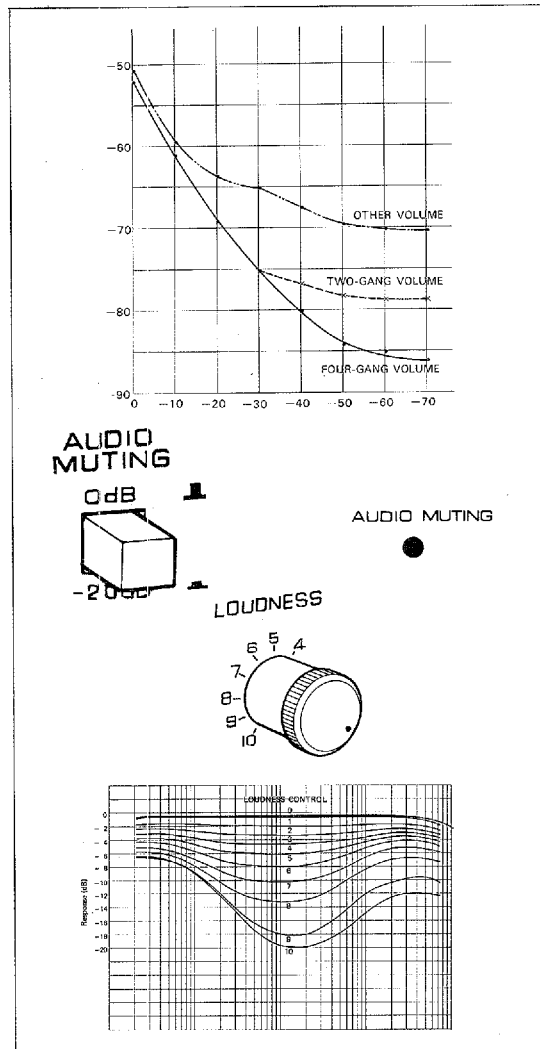

THE SPECIAL 4-GANG VOLUME CONTROL

The CR-2020 features ganged volume controls in positions both before and after the tone-control circuits, in both channels, a total of four precision ganged volume controls in all. This gives a considerable gain in signal-to-noise ratio at normal listening levels, as shown in the graph. The vertical arrows show the gain over conventional volume controls. The control is continuous, and the stereo balance extremely precise, with an attenuation curve that gives gently graduated volume changes at all listening levels. Always start listening to a new program source with the volume turned well down, and turn up as necessary.

THE AUDIO MUTING SWITCH

This offers an instant reduction of 20 dB in level without needing to touch the volume control. It should be used whenever switching between different program sources, when raising and lowering the cartridge stylus in record audition, and when the level must be cut to answer the telephone, etc.

Take great care *not* to release the AUDIO MUTING switch to the 0 dB position without reducing the volume: a sudden increase of 20 dB above normal listening levels might be enough to damage your speakers. The indicator LED for AUDIO MUTING is a visual reminder when this is ON.

THE CONTINUOUS LOUDNESS CONTROL

The CR-2020 is unusual in providing a separate volume control for continuous loudness compensation. Most receivers and amplifiers feature a loudness switch designed to compensate for the reduced sensitivities of our ears to high and low frequencies at low listening levels. However, the CR-2020 improves on such on/off switches, which can only offer a certain fixed degree of compensation at any given volume level, by enabling a degree of loudness compensation which can be matched to the listening situation — and listening level — of the user. The graph on the left shows the different degrees of compensation given at different settings.

First turn the LOUDNESS control fully clockwise to the FLAT position, then adjust the main volume control to the maximum listening level you will normally be using. Make any further adjustments to the tone controls at the maximum level. Then use the LOUDNESS control, rather than the main VOLUME control itself, to reduce the listening level when necessary. The same tonal balance will be preserved at all levels.

ACCURATE, WIDE-LEVEL METERS

These meters enable you to read the output power levels of the CR-2020. Their response speed is high enough to give accurate readings of output levels. Note that instantaneous levels can exceed the nominal rated power of 100 Watts rms per channel. (Note also that the meters are calibrated accurately for output power into standard 8 ohm speakers, but that corrections must be applied if speakers with different impedances are used. For 4 ohm speakers the readings should be multiplied by two (i.e. a reading of 50 Watts indicates an output power of 100 Watts), and for 16 ohm

speakers the reading should be divided by two (i.e. a reading of 50 Watts is really only an output power of 25 Watts).

THE SP OUT/SIGNAL Q SWITCH

This push-button switch, immediately above the power switch, should normally be in the SP OUT position. Under these circumstances the left-hand and center meters will normally indicate the levels of the left and right hand channels outputs respectively. However, as soon as the tuning knob is touched, the central meter reverts to the SIGNAL Q function described in the section on FM broadcast reception, and the left-hand meter ceases to read.

When this switch is depressed, the meter on the left will not register, and the central meter will permanently indicate signal strength and signal quality. It should therefore only be used when you need to see these readings without having to touch the tuning knob, for instance when watching for the antenna orientation which gives the best signal strength or the greatest freedom from the fluctuation that indicates interference waveforms.

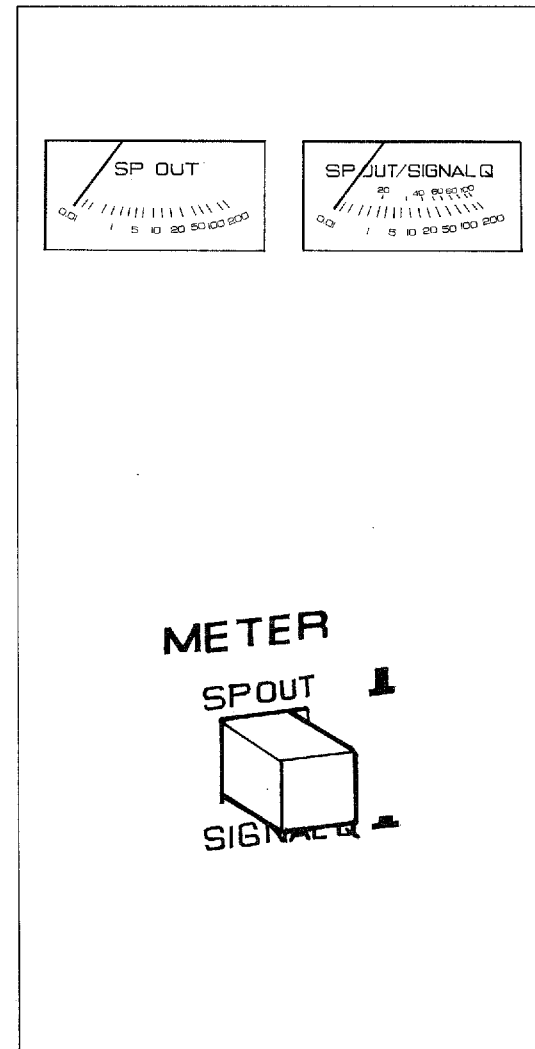

CR-2020

TONE CONTROLS

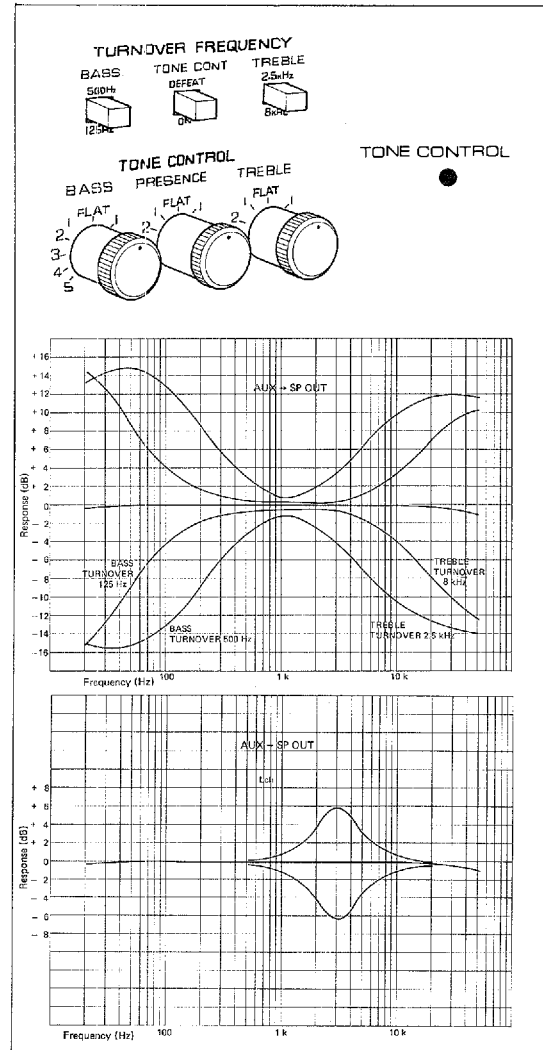

COMPREHENSIVE TONE CONTROLS

In addition to the normal bass and treble controls provided on most amplifiers and receivers, there is a special PRESENCE control for the mid-range frequencies. The bass and treble controls, too, have twin turnover frequencies, so that the degree of tone control possible with the CR-2020 is unusually large. Be sure to depress the DEFEAT button (to the ON position) or these controls will not function. The TONE indicator LED gives visual confirmation.

TWIN TURNOVER FREQUENCIES

With the turnover frequency selection push-button switches in the released (i.e. projecting) positions, the bass and treble turnover frequencies are 500 Hz and 2.5 kHz respectively, so that the control settings have a marked influence at the extreme upper and lower frequencies, and extending even down into the mid-frequency range. Use these settings for major corrections of tonal quality. With both turnover frequency selector buttons depressed, the effect of the two controls is limited more closely to the frequency extremes, leaving the mid-range frequencies unaffected. Use the

8 kHz setting to tone down an over-brilliant recording, or to compensate for a very 'live' listening room (one with few sound-absorbent drapes or soft furnishings and many hard, reflecting surfaces). Use the 125 Hz setting when you wish to boost the very low bass region (bass drums, etc.) without 'thickening' the tone of the lower mid-range. The best way to try their effect is to compare the settings by pressing and releasing the DEFEAT push-button, so that any improvement is instantly audible.

THE PRESENCE CONTROL

This control, which produces variations in the mid-frequency response centered about 3 kHz, is extremely effective in giving control of program source tonal character. Conventional bass and treble controls barely extend their influence to the important mid-range frequencies. The special PRESENCE control offers direct control of these frequencies, readily compensating for recordings which have a 'heavy' or 'thin' mid-range characteristic, and offering new possibilities for delicate tonal coloration.

CR-2020

FILTERS AND MODE SELECTION

COMPREHENSIVE FILTERING

The filter circuits of the CR-2020 offer an unusually wide range of filter functions, combining a choice of two frequencies each for high and low cut-off, with very steep cut-off attenuation slopes (a full 12 dB/octave). This sharp slope is achieved with extremely low distortion, so that unwanted high and low frequencies can be eliminated with the minimum degradation of tonal quality in the important frequencies which carry most of the musical signal.

THE CHOICE AND USES OF THE LOW FREQUENCY FILTERS

The two frequencies available are 15 Hz and 70 Hz, at which frequencies the cut-off attenuation has already reached 3 dB (a small but readily detectable difference), and below which the cut-off is very sharp. The frequency response of the CR-2020 is so flat, well into subsonic frequencies, that the ultra-low signals arising from warped or eccentric records can be amplified and fed to the speakers at quite high levels. These signals can give rise to cross-modulation distortion (a general 'muddiness' and lack of clarity), and in severe cases can seriously overload the speakers. If the LOW filter is set at 15 Hz, these non-musical signals can be safely eliminated at virtually no sacrifice in tonal quality due to the low distortion circuitry used.

For the audible rumble that an aging (or not very high quality) turntable can give, the higher frequency of 70 Hz should be used, but there will also be some loss of lower frequency signals (drums and basses, etc).

THE CHOICE AND USES OF THE HIGH FREQUENCY FILTERS

The two HIGH frequency filters commence their very rapid cut-off at 8 kHz or 12 kHz. They can be used to cut out unwanted tape hiss or record scratch (which becomes more obtrusive at higher frequencies). The use of the 8 kHz filter involves considerable sacrifice of the brilliant upper harmonics which add character to brass and stringed instruments. This is also true, but to a lesser extent, with the 12 kHz filter. Only you can decide whether the program source is more enjoyable with — or preferably without — these filters.

THE MODE SWITCH

Use this to check the output from left and right-hand channels independently, or to listen in monaural instead of stereo. You can also correct for a mistake in connecting L and R terminals by reversing the stereo reproduction although it is better to correct the connections.

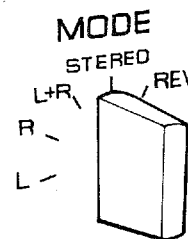
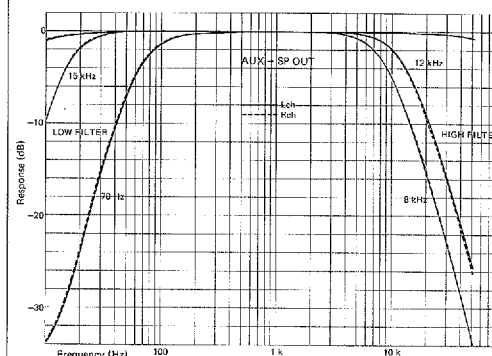
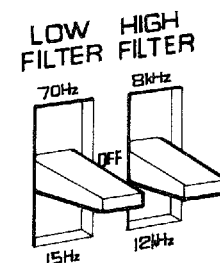

CR-2020

BLOCK DIAGRAM

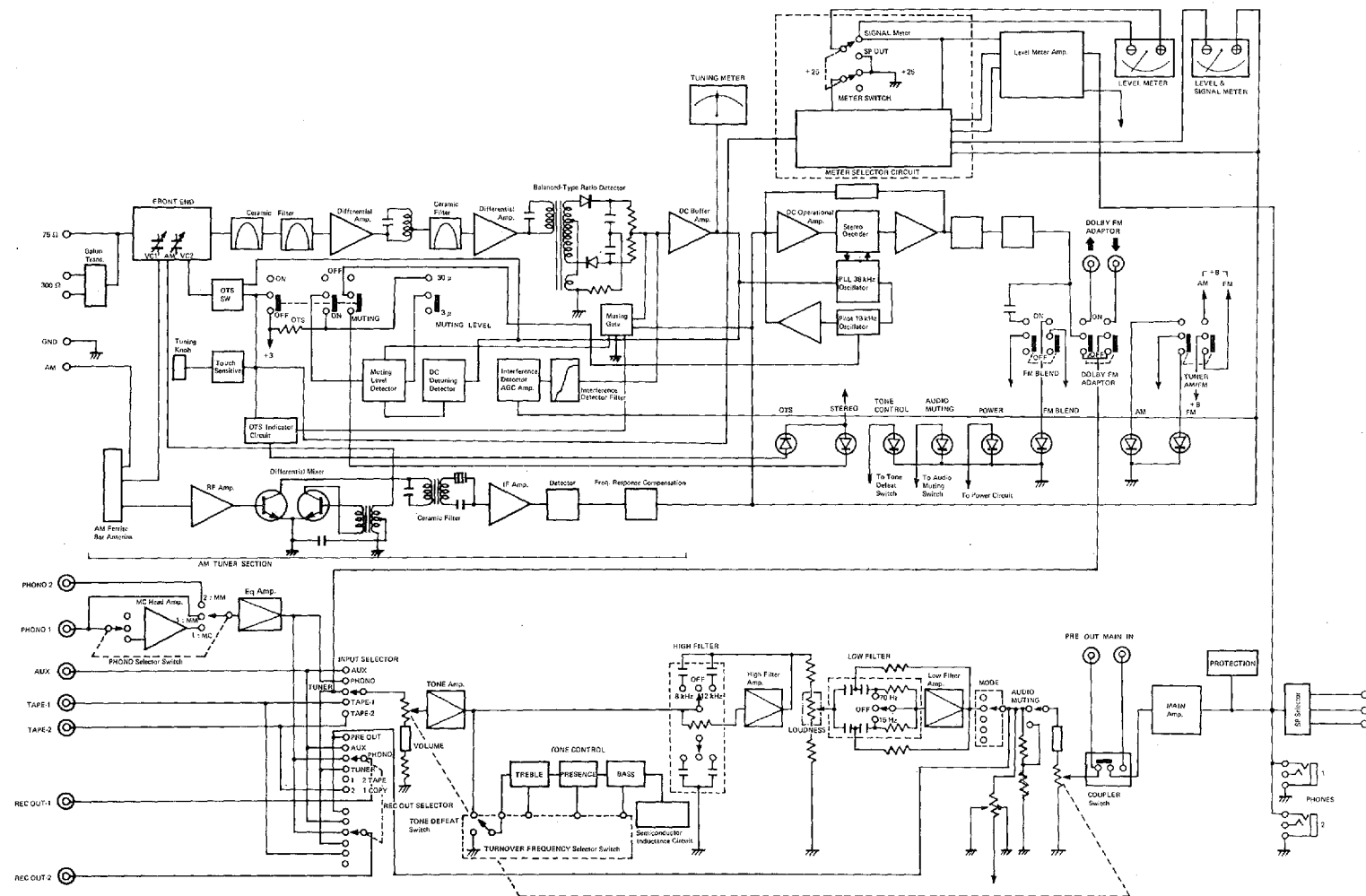

CR-2020

CIRCUIT DIAGRAM

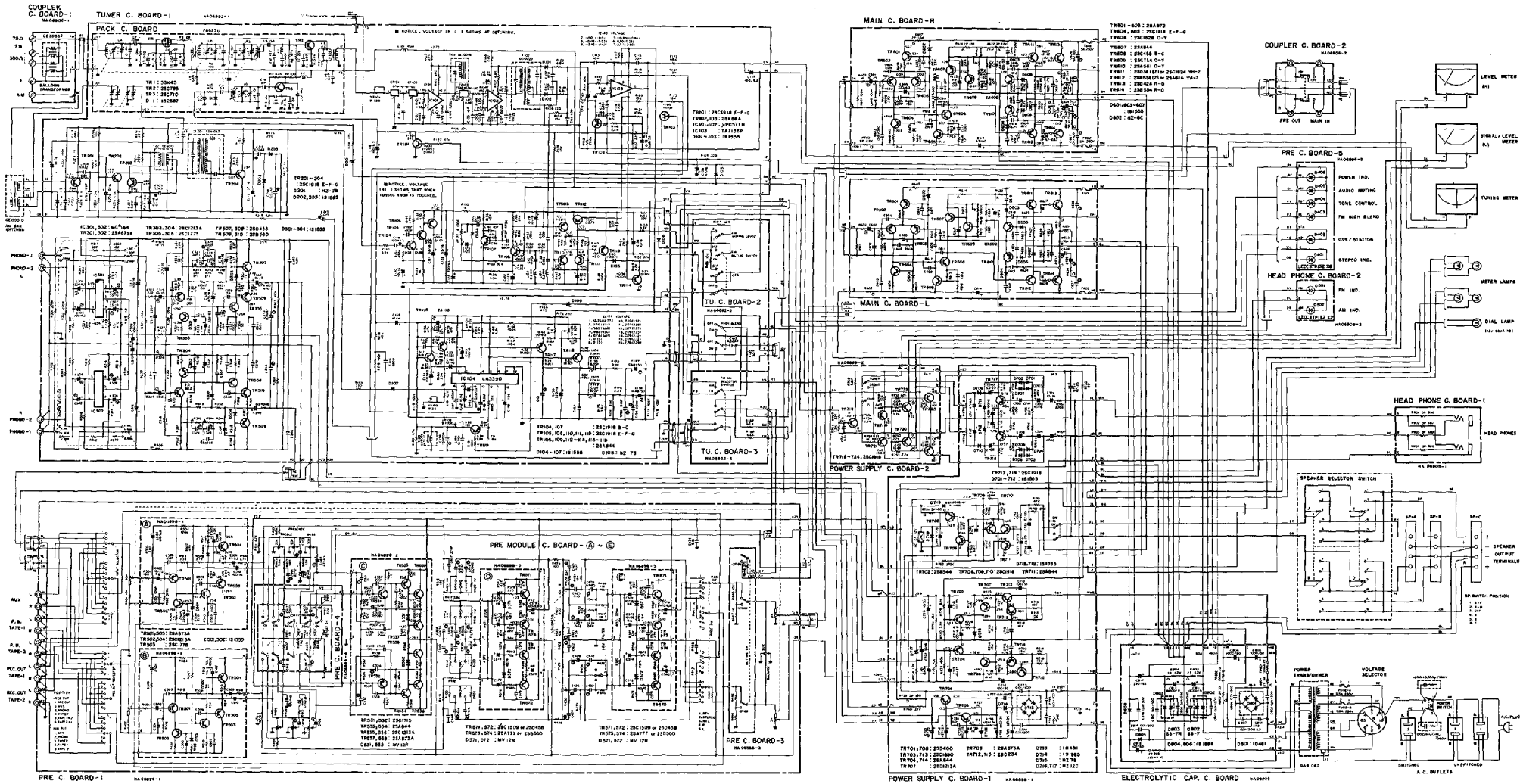

RESISTORS
 □ CARBON FILM RESISTOR
 △ METAL FILM RESISTOR
 ▲ METALIZED SILICON RESISTOR
 ■ WIRE WOUND RESISTOR

RESISTOR MARKINGS
 □ METAL FILM RESISTOR
 △ CARBON FILM RESISTOR
 ▲ SILICON RESISTOR
 ■ WIRE WOUND RESISTOR

WIRE COLOR ABBREVIATIONS
 BK - BLACK, BK - BROWN, BR - BROWN, GR - GREEN, WH - WHITE, RD - RED, OR - ORANGE, YL - YELLOW, GN - GREEN, BL - BLUE, V - VIOLET, PK - PINK

CAPACITORS
 □ 100 P.F. CAPACITOR
 ○ AIR CORE CAPACITOR
 ○ POLYMER CAPACITOR
 ○ ELECTROLYTIC CAPACITOR
 ○ VARIABLE CAPACITOR

CAPACITOR MARKINGS
 □ 100 P.F. CAPACITOR
 ○ AIR CORE CAPACITOR
 ○ POLYMER CAPACITOR
 ○ ELECTROLYTIC CAPACITOR
 ○ VARIABLE CAPACITOR

WIRE COLOR ABBREVIATIONS
 BK - BLACK, BK - BROWN, BR - BROWN, GR - GREEN, WH - WHITE, RD - RED, OR - ORANGE, YL - YELLOW, GN - GREEN, BL - BLUE, V - VIOLET, PK - PINK

CR-2020

SPECIFICATIONS

AUDIO SECTION

Minimum RMS Output Power per Channel

100 Watts (8 ohms) from 20 to 20,000 Hz at no more than 0.05% Total Harmonic Distortion

Continuous RMS power	
(both channels driven, 1 kHz)	105 Watts (8 Ω)
Input Sensitivity/Impedance	
Phono 1, 2 (MM)	2 mV/47 k Ω
Phono 1 (MC)	50 μ V/10 Ω
Aux, Tape 1, 2	120 mV/45 k Ω
Main In terminals	775 mV/100 k Ω
Maximum Input Levels	
Phono 1, 2 (MM)	230 mV (at 1 kHz)
Phono 1 (MC)	5 mV (at 1 kHz)
Output Level/Impedance	
Rec Out terminals (Phono)	120 mV/500 Ω (rated)
	15 V (max. 1 kHz)
Pre Out terminals (rated)	775 mV/0 – 2 k Ω (5 V max.)
Frequency Response	
Phono 1, 2 (MM, MC) RIAA deviation	\pm 0.2 dB
Aux, Tape 1, 2 to Sp Out	10 Hz to 100 kHz \pm 2.5 dB
Main In to Sp Out	10 Hz to 100 kHz \pm 2.5 dB
Tone Control Characteristics	
Bass turnover frequencies	125 and 500 Hz
Bass boost/cut	\pm 15 dB at 20 Hz
Treble turnover frequencies	2.5 and 8 kHz
Treble boost/cut	\pm 12 dB at 20 kHz
Presence boost/cut	\pm 6 dB at 3 kHz
Filters and Loudness Control Characteristics	
Low	15 and 70 Hz (12 dB/octave)
High	8 and 12 kHz (12 dB/octave)
Loudness control	Level-related equalization

Signal-to-Noise Ratio (IHF-A Network)	
Phono 1, 2 (MM)	95 dB (for 10 mV, shorted)
Phono 1 (MC)	85 dB (250 μ V, 50 Ω shorted)
Aux, Tape	100 dB (5.1 k Ω , shorted)
Main	112 dB (5.1 k Ω , shorted)
Residual noise (at Vol Min)	0.045mV
Total Harmonic Distortion, 20 Hz to 20 kHz	
Phono 1, 2 (MM) to Rec Out	0.01% 7.5 V output
Phono 1 (MC) to Rec Out	0.05% 3 V output
Aux, Tape to Sp Out (8 Ω)	0.02% at 50 W
Main In to Sp Out (8 Ω)	0.015% at 50 W
IM Distortion Aux to Sp Out	0.05% at 100 W

Noise-Distortion Clearance Range (NDCR) for 0.1% into 8 Ω at 20 Hz to 20 kHz

From 100 mW to 100 Watts with Vol –20 dB (Phono Input (MM) to Sp Out)

Power bandwidth (IHF)	10 Hz to 50 kHz (at 0.05% THD)
Damping factor (at 1 kHz)	40 into 8 Ω
Meter Range	100 mW to 200 W into 8 Ω
FM SECTION	
Tuning range	88 to 108 MHz
Usable Sensitivity	
300 Ω	10.3 dBf/1.8 μ V
75 Ω	10.3 dBf/0.9 μ V
Quieting characteristics (for 50 dB signal-to-noise)	
Mono	15.3 dBf (3.2 μ V)
Stereo	37.2 dBf (40 μ V)

Image Rejection (98 MHz)	85 dB
IF Rejection (98 MHz)	90 dB
Spurious Rejection (98 MHz)	100 dB
AM Suppression (IHF)	65 dB
Capture Ratio	1.0 dB
Usable Selectivity (IHF)	80 dB
Signal-to-Noise Ratio (IHF)	
Mono	77 dB
Stereo	73 dB
Total Harmonic Distortion	
Mono 100 Hz	0.08%
1 kHz	0.08%
6 kHz	0.15%
Stereo 100Hz	0.15%
1 kHz	0.1%
6 kHz	0.2%
Intermodulation Distortion (IHF)	
Mono	0.05%
Stereo	0.1%
Sub-Carrier Suppression	60 dB
Stereo Separation	
50 Hz	35 dB
1 kHz	50 dB
10 kHz	45 dB
Frequency Response	
50 Hz to 10 kHz	± 0.3 dB
30 Hz to 15 kHz	± 0.5 dB
10 Hz to 18 kHz	+ 0.5 -3.0 dB

Muting Levels	34.8 dBf/30 μ V and 14.8 dBf/3 μ V
AM SECTION	
Tuning Range	525 to 1,605 kHz
Sensitivity (IHF, bar antenna)	300 μ V/m (49 dB/m)
Selectivity (1,000 kHz)	30 dB
Signal-to-Noise Ratio	50 dB (at 80 dB/m)
Image Rejection (1,000 kHz)	55 dB
IF Rejection (1,000 kHz)	40 dB
Spurious Rejection (1,000 kHz)	55 dB
Total Harmonic Distortion	0.4% (at 80 dB/m)
Tuner Section Output Level/Impedance	
FM (100% mod. at Rec Out)	450 mV/6.5 k Ω
AM (30% mod. at Rec Out)	120 mV/6.5 k Ω
GENERAL	
Semiconductors	109 Transistors, 6 ICs, 3 FETs, 58 Diodes, 7 Zener Diodes, 8 LEDs, 4 Ceramic Filters.
Power Supplies	U.S.A. and Canada AC 120 V, 60 Hz Australia AC 240 V, 50 Hz Other Areas 110/120/130/220/230/240V, Switchable; 50/60 Hz.
Power Consumption	480 W (Aust. 690 W)
Dimensions (W x H x D)	540 x 167 x 415 mm (21-1/4" x 6-9/16" x 16-5/16")
Weight	19.3 kg (42 lb 7 oz)

CR-2020

TROUBLE SHOOTING

Before assuming that your CR-2020 is faulty, check the following trouble-shooting list, which details many steps you can take yourself, without having to call a service representative.

AUDIO SECTION

Fault	Cause	Cure
No power although POWER switch is ON (POWER LED unlit)	AC power line not plugged into supply socket. AC main fuse has blown.	Plug firmly into the supply socket. Contact your service rep. for a replacement.
No sound although power is connected.	Volume too low. INPUT SELECTOR in wrong position. Input pin plugs incorrectly inserted, loose, or disconnected. Speaker connections faulty. SPEAKERS switch OFF. PRE OUT/MAIN IN COUPLER switch in OFF position.	Turn up volume. Check and change as necessary. Check and insert fully in the correct positions. Check and make good. Set to correct position. Switch back to ON.
Sound comes only, or mainly, from either L or R speaker	Speaker connections faulty. Input connections faulty. BALANCE control not properly adjusted.	Check and make good. Check and make good. Set to give correct stereo balance.
Sound suddenly ceases during audition.	The protective circuit has gone into operation. AC main fuse has blown.	Check for incorrect (too low) speaker impedances or short-circuits and correct. If the fault persists, switch off and wait briefly before switching on again. Contact your service rep. for replacement.
Poor bass response and badly defined stereo image.	Speaker + and - connections are incorrect.	Reverse the connections to one speaker, not both.
A loud 'humming' is heard with, or instead of, the record when attempting PHONO audition.	Either the pin-plugs from the phono cartridge are not firmly plugged into the input sockets, or the braided shielding wire is defective.	Plug in firmly, replacing the defective shielding if necessary. Check and make good the GND (ground) wire connection.
The volume control cannot be raised during record audition without a loud 'booming' noise.	This is caused by acoustic feedback from the speakers to the phono cartridge stylus.	Increase the separation between turntable unit and speakers, avoiding locations directly in line with the speakers.
The volume is inadequate even when fully raised.	The AUDIO MUTING switch is on.	Reduce the volume first, then switch the AUDIO MUTING off.
The tone controls have no effect.	The DEFEAT switch is operative.	Push into the ON position.
Bass and treble frequencies are unnaturally exaggerated.	The LOUDNESS volume control is set too low.	Turn to the FLAT position (fully clockwise) and re-set main and LOUDNESS volume controls according to the instructions.
Your tape recorder does not record the program you are monitoring.	The REC OUT selector is not set to the required program source.	Turn to the required setting.

TUNER SECTION

Fault	Cause	Cure
A persistent hum occurs when an AM station is tuned.	This modulation hum can affect whole areas where conditions are unfavorable.	Sometimes changing the position of the CR-2020 will give an improvement.
Intermittent crackling or continuous background 'roaring' on AM.	Atmospheric electricity or electrical storms; possibly fluorescent lighting or other electrical equipment.	Difficult to eliminate, an external antenna and good ground connection will give considerable improvement.
High pitched whistles, etc., particularly at night, on AM.	Signals from adjacent stations are interfering with reception. The CR-2020 is being operated near a TV set.	Nothing can be done to cut out this interference, but try the 8 kHz filter. Increase the distance between the TV and the CR-2020.
No FM broadcasts can be received.	The FM DOLBY adaptor switch is ON although you have no adaptor.	Switch it off.
The desired station cannot be received at the correct frequency on the dial.	The station strength is low, and the MUTING circuit is preventing audition.	Switch from 30 μ V to 3 μ V, or from 3 μ V to off.
A stereo station is heard in mono.	The amplifier MODE switch is on L + R. The FM MUTING switch is on OFF/FM MONO.	Switch to STEREO. Switch to ON.
Occasional crackling interference (particularly with remote, weak signal stations).	Electrical noise from automobiles, etc., or from other electrical equipment.	Set up an external FM antenna, as high and as far from the road as convenient, using coaxial cable; fit an interference suppressor to the offending equipment.
Disturbing degree of 'hiss' noise when on FM stereo stations.	FM stereo broadcasts are inherently more liable to this at remote, low signal strength locations.	Set up an external FM antenna; if you are already using one, orient it towards the station or replace with a more sensitive array. Alternatively or additionally, listen at FM BLEND or MUTING OFF/FM MONO positions.
Local stations suffer from unclear, distorted sound.	Signal input from the antenna for these stations is too strong.	Connect an attenuator between the AM antenna and the CR-2020, or turn the antenna away from the strongest (closest) station.
During stereo test transmissions, sounds which should come from only one channel can be heard faintly over the other.	This is known as crosstalk, and normally occurs to some extent.	Provided the sound level is very faint compared with the normal level for that channel, no fault is indicated.



SINCE 1887  **YAMAHA**
NIPPON GAKKI CO., LTD., HAMAMATSU, JAPAN

